

## 2.5MM LUXURY FLOORING

**Duo™**

### Product Information

**Construction** - Solid Vinyl Tile (Luxury Vinyl Tile / LVT)

**International Specifications** - ASTM F 1700, Class III, Type B embossed surface

**Overall Thickness** - 2.5 mm (0.100 in.)

**Wear Layer Thickness** - 20 mil (0.5 mm)

**Factory Finish** - Diamond 10® Technology

**Installation** - Adhesives: S-315 Roll Strong™, S-980, S-1000, S-240 Epoxy

**Maintenance Options** - No Polish - No Buff, Polish Optional

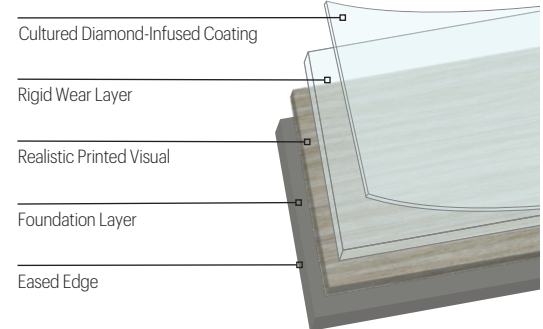

### Packaging

Size	Pieces per Carton/Coverage	Shipping Weight per Carton
6 in. x 36 in. (152 mm x 914 mm)	24 / (36 sq. ft.) 3.35 m <sup>2</sup>	55.80 lbs. (25.31 kg)
18 in. x 36 in. (457 mm x 914 mm)	12 / (54 sq. ft.) 5.02 m <sup>2</sup>	55.80 lbs. (25.31 kg)

### Testing

ASTM F1700			
Performance	Test Method	Requirement	Performance vs. Requirement
Thickness	ASTM F386	Nominal ±0.005 in.	Meets
Wear Layer Thickness	ASTM F410	0.020 in. (0.5 mm) minimum for Commercial Use	Meets
Size	ASTM F2421	± 0.016 in. per linear foot	Meets
Squareness	ASTM F2421	0.010 in. maximum	Meets
Residual Indentation	ASTM F1914	Average less than 8%	Meets
Chemical Resistance	ASTM F925	No more than slight change in surface dulling, attack or staining	Meets
Resistance to Heat	ASTM F1514	ΔE < 8 avg., max	Meets
Resistance to Light	ASTM F1515	ΔE < 8 avg., max	Meets
Additional Testing			
Static Load Resistance	ASTM F970*	≤ 0.005 in.	2000 psi
Dimensional Stability	Internal	≤ 0.018 in. per linear ft. MD	Meets
		≤ 0.012 in. per lin. ft. AMD	
Fire Test Data – Flame Spread	ASTM E648	0.45 W/cm <sup>2</sup> or more Class 1	Meets
Fire Test Data – Smoke Evolution	ASTM E662	450 or less	Meets
Fire Test Data – Canada	CAN/ULC S-102.2	Use dependent	Flame Spread - 5   Smoke Developed - 75
ADA Standards for Accessible Design	Chapter 3, Section 302.1	Floor surfaces shall be stable, firm and slip resistant	Meets
Static Coefficient of Friction**	ASTM D2047/UL 410	≥ 0.5	Meets
Acoustics	ASTM E492 ASTM E90 ASTM E2179	IIC ≥ 50 (International Building Code)	Exceeds - IIC 53
		STC ≥ 50 (International Building Code)	Exceeds- STC 51
		Sound Transmission Reduction	ΔIIC - 22 6 in. concrete, no ceiling with S-1840 Quiet Comfort Luxury Flooring Underlayment

## 2.5MM LUXURY FLOORING

**Duo™**

### Sustainability

#### WELL v1 Feature

	WELL v1 Feature	Duo	Contribution
Air	Feature 04 - VOC Reduction	✓	Tested and third party certified by FloorScore as complying with CDPH v1.2
	Feature 11 - Fundamental Material Safety	✓	Product is free of asbestos and added lead (Part 1)
	Feature 25 - Toxic Material Reduction	✓	Free of flame retardants (Part 2) and phthalates (Part 3)
Mind	Feature 97 - Material Transparency	✓	Readily available Health Product Declaration (HPD) to 1000 ppm
	Feature 88 (Part 2) Biophilia I - Qualitative	✓	Products available that incorporate nature patterns
	Feature 99 - Beauty and Design II	✓	Patterns and colors to aid in wayfinding and spatial familiarity (Part 3)

#### WELL v2 Feature

	WELL v2 Feature	Duo	Contribution
Materials	Feature X01.1 Material Restrictions	✓	Product is free of asbestos
	Feature X05.1 Enhanced Material Restrictions	✓	Free of flame retardants (Part 2) and phthalates (Part 3)
	Feature X06.1 VOC Restrictions	✓	Adhesives associated with product are tested and third party certified by FloorScore as complying with CDPH v1.2
	Feature X06.2 VOC Restrictions	✓	Flooring is tested and third party certified by FloorScore as complying with CDPH v1.2
	Feature X07.1 Material Transparency	✓	Readily available Health Product Declaration (HPD) to 1000 ppm
	Mind	Feature M02.1 Nature and Place	✓
Community Feature C13 (Part 2) Accessibility and Universal Design		✓	Provided patterns and colors to aid in wayfinding and spatial familiarity

#### LEED™ v4.1

	LEED™ v4.1	Duo
	BPDO - EPD	Third party certified Product Specific
	BPDO - Material Ingredient	HPD
	BPDO - Sourcing	29% pre-consumer recycled content
	Location of Manufacturer	USA
	Low Emitting Flooring	Tested and third party certified by FloorScore as complying with CDPH v1.2
	Low Emitting Adhesives	Tested and compliant to CDPH v1.2; Methylene Chloride and Perchloroethylene not intentionally added; FloorScore Certified
	SCAQMD #1168 Compliant.	S-240 Epoxy – 10 g/L
	Adhesives meet >50 g/L requirement	S-315 Roll Strong – 0 g/L
		S-980 – 14 g/L
		S-1000 – 0.1 g/L

### Limited Warranty

20-year Commercial Warranty when installed in strict accordance with the detailed instructions.

### Visit ArmstrongFlooring.com

for complete Product, Technical, Adhesives, Installation & Maintenance recommendations.

F-10666-721

Armstrong and the Armstrong logo are under license from AWI Licensing LLC. | All other trademarks are owned by AFI Licensing LLC. | © 2021 AFI Licensing LLC. FloorScore® is a registered trademark of the Resilient Floor Covering Institute. | LEED® is a registered trademark of the United States Green Building Council

\*Testing at loads above 250 psi is outside the scope of the test method. Since testing is conducted on uninstalled flooring, results do not consider the performance of the adhesive, underlayment, or subfloor. These test results are not an indicator of the installed flooring system performance. \*\*Using the James Machine as described in D2047 and as directed in UL 410 for floor covering materials (FCM) using a leather foot under dry conditions. The application of site-applied floor sealers, polishes and other types of finishes routinely used to maintain resilient flooring materials will change the walking surface and consequently the SCOF value.

