

PRODUCT SPEC PAGE

Unbound™ with Diamond 10® Technology LVT Luxury Flooring

Product Information

Construction	Product Line	International Product Specifications	Overall Thickness Wear Layer Thickness	Factory Finish	Installation	Maintenance Options
Solid Vinyl Tile (a.k.a. Luxury Vinyl Tile - LVT)	Unbound™ with Diamond 10® Technology LVT	ASTM F 1700, Class III, Type B embossed surface	0.200 in. (5.0 mm) 0.020 in. (0.5 mm)	Diamond 10® Technology – Cultured Diamond Infused Coating	Looselay, Modified Looselay or Full Spread Adhesives: S-315 Roll Strong™, S-288 Premium, S-1000	No Polish – No Buff, Polish

Packaging

Tile Sizes	Tiles per Carton/ Coverage	Shipping Weight per Carton
7 in. x 59 in. (178 mm x 1499 mm)	8 - 23.92 ft² (2.22 m²)	44.18 lbs./carton (20.4 kg)
9 in. x 59 in. (229 mm x 1499 mm)	6 - 22.31 ft² (2.07 m²)	41.9 lbs./carton (18.99 kg)
36 in. x 36 in. (914 mm x 914 mm)	4 - 36 ft² (3.34 m²)	63.4 lbs./carton (28.78 kg)

Product Structure

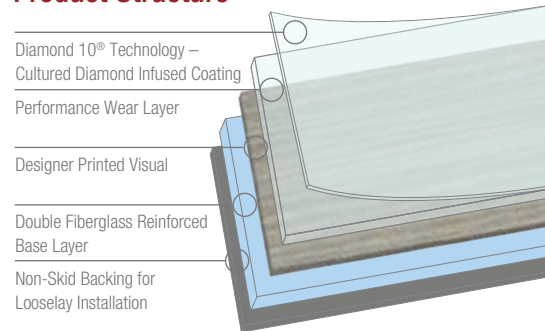

Testing

	Performance	Test Method	Requirement	Performance vs. Requirement
ASTM F 1700	Thickness	ASTM F 386	Nominal ± 0.005 in.	Meets
	Wear Layer Thickness	ASTM F 410	0.020 in. (0.5 mm) minimum for Commercial Use	Meets
	Squareness	ASTM F 2055 (tile) ASTM F 2055 (plank)	0.010 in. maximum	Meets
	Dimensional Stability	ASTM F 2199	≤ 0.020 in. per linear foot	Meets
	Chemical Resistance	ASTM F 925	No more than slight change in surface dulling, attack or staining	Meets
	Resistance to Heat	ASTM F 1514	ΔE < 8	Meets
	Resistance Light	ASTM F 1515	ΔE < 8	Meets
	Static Load Resistance	ASTM F 970	≤ 0.005 in.	Passes
	Static Load Resistance	ASTM F 970*	< 0.005	1000 psi
	Fire Test Data – Flame Spread	ASTM E 648	0.45 W/cm² or more Class I	Meets
Additional Testing	Fire Test Data – Smoke Evolution	ASTM E 662	450 or less	Meets
	Fire Test Data – Canada	CAN/ULC S102.2	Use dependent	Flame Spread - 25 Smoke Developed - 230
	ADA Standards for Accessible Design	Chapter 3 Section 302.1	Floor surfaces shall be stable, firm and slip-resistant	Meets
	Static Coefficient of Friction**	ASTM D2047/ UL 410	≥ 0.5	Meets

* Testing at loads above 250 psi is outside the scope of the test method. Since testing is conducted on uninstalled flooring, results do not consider the performance of the adhesive, underlayment, or subfloor. These test results are not an indicator of the installed flooring system performance.

** Using the James Machine as described in D2047 and as directed in UL 410 for floor covering materials (FCM) using a leather foot under dry conditions. The application of site-applied floor sealers, polishes and other types of finishes routinely used to maintain resilient flooring materials will change the walking surface and consequently the SCOF value.

PRODUCT SPEC PAGE

Unbound™ with Diamond 10® Technology LVT

Luxury Flooring

Sustainability

Certification Attribute	Standard	3rd party Certification/Certifier
Low Emitting Material	CDPH v1.1 (2017) a.k.a CHPS 01350	FloorScore/SCS
Environmental Product Declaration (EPD)	ISO 14025 and ISO 14040	Certified/ULE

Performance	Standard	Requirements	Performance vs. Requirements
TVOC Range	CDPH v1.1 (2017) a.k.a CHPS 01350	<0.5 mg/m ³	Meets
Low Emitting Adhesives S-288 S-315 S-1000	FloorScore®/SCAQMD	Less than 50 g/L	S-288 Exceeds - 14 g/L S-315 Exceeds - 0 g/L S-1000 Exceeds - 0.1 g/L
Acoustics	ASTM E492 ASTM E90 ASTM E2179	Impact Insulation Class Sound Transmission Class Sound Transmission Reduction Radiated	IIC - 42 (6" concrete - no ceiling) STC - 52 (6" concrete - no ceiling) Delta IIC (ΔIIC) - 15
Fundamental Material Safety Toxic Materials Reduction	WELL® Feature 11 and Feature 25	No Asbestos, free of lead and phthalates (DEHP, DBP, BBP, DINP, DNOP)	Meets

Limited Warranty

20-year Commercial Limited Warranty when installed in accordance with the Armstrong Flooring Guaranteed Installation Systems manual, F-5061.

ArmstrongFlooring.com/commercial | 1 888 276 7876

