

PRODUCT SPEC PAGE

Rigid Core Vantage™

Rigid Core Flooring

Product Information

Construction	Product Line	International Product Specifications	Overall Thickness Wear Layer Thickness	Factory Finish	Installation	Maintenance Options
Rigid Core	Vantage™	ASTM F 3261, Class I, Type B, Grade 1, Backing Class B	0.236" (6 mm) 20 mil (0.5 mm)	Urethane	Drop-lock or S-288 full spread	No Polish - No Buff Spray Buff, Polish

Packaging

Tile Sizes

7 in. x 60 in. (177.8 mm x 1,524 mm)
9 in. x 60 in. (225 mm x 1,524 mm)

Tiles per Carton/ Coverage

7 in. x 60 in. – 6
(17.5 sq. ft.) 1.62 m²
9 in. x 60 in. – 6
(22.1 sq. ft.) 2.05 m²

Shipping Weight per Carton

34.26 lbs. (15.54 kg)
43.35 lbs. (19.66 kg)

Product Structure

Embossed-in-register texture adds realism on Rigid Core Vantage™ R

20 mil wear layer with urethane coating

Painted 4-sided bevels

Dense polymer composite waterproof* core

Quick & easy drop-lock

Acoustic cork backing

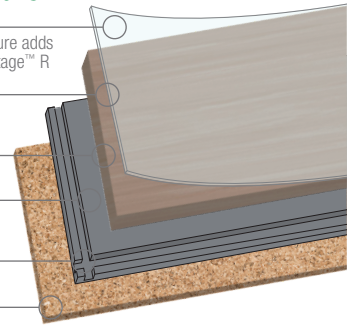

Testing

Performance	Test Method	Requirement	Performance vs. Requirement
Thickness	ASTM F 387	As specified ±0.008 in. (0.20 mm)	253 mils +/-0.008 in.
Wear Layer Thickness	ASTM F 410	0.020 in. (0.5 mm) minimum for Commercial Use	Meets
Size	ASTM F 2055 ISO 24337	± 0.016 in. per linear foot	Meets or exceeds
Squareness	ASTM F 2055	0.010 in. maximum	Meets or exceeds
Flatness - Max	ISO 24337	Fw ± 0.008 in. (0.2mm) for planks or tiles ≤ 9 in. (229 mm) wide Fw concave ≤ 0.15% / Fw convex ≤ 0.20% for all other widths Fl concave ≤ 0.50% / Fl convex ≤ 1.00%	Meets or exceeds
Openings, Avg / Max	ISO 24337	Oavg ≤ 0.004 in. (0.1 mm) / OM ≤ 0.008 in. (0.2 mm)	Meets
Ledging, Avg / Max	ISO 24337	Havg ≤ 0.004 in. (0.1 mm) / HM ≤ 0.006 in. (0.15 mm)	Meets or exceeds
Residual Indentation	ASTM F1914	Avg. ≤ 0.007 in. (0.18 mm)	Meets or exceeds
Surface Integrity	ASTM F1914	No puncture thru wear layer/décor in to rigid core	Meets or exceeds
Dimensional Stability	ASTM F2199 ISO 23999	0.2% per lin. ft (305 mm)	Meets or exceeds commercial requirements
Curl	ASTM F2199 ISO 239999	Max 0.080 in. (2 mm)	Meets or exceeds
Chemical Resistance	ASTM F 925	No more than slight change in surface dulling, attack or staining	Meets
Resistance to Heat	ASTM F 1514	ΔE < 8 avg., max	Meets or exceeds
Resistance to Light	ASTM F 1515	ΔE < 8 avg., max	Pass, Class 4 Heavy Commercial
Castor Wheel	EN 425	25,000 cycles - No effect	Exceeds; meets 35,000 cycles (NALFA 3.9 Heavy Commercial)

PRODUCT SPEC PAGE

Rigid Core Vantage™

Rigid Core Flooring

Testing Continued

	Performance	Test Method	Requirement	Performance vs. Requirement
ADDITIONAL TESTING	Static Load Limit	ASTM F970 ASTM F387	Max loading: 250 lb/in ² (1.72 MPa) Max residual indent: 0.005 in. (0.013 mm)	Meets or exceeds commercial requirements; Pass at 1450 psi
	Fire Test Data – Flame Spread	ASTM E648	0.45 W/cm ² or more Class 1	Pass
	Fire Test Data – Canada	CAN/ULC S-102.2	Use dependent	Flame Spread -15 Smoke Developed - 215
	Static Coefficient of Friction*	ASTM D2047/UL 410	≥ 0.5	Meets

* Using the James Machine as described in D2047 and as directed in UL 410 for floor covering materials (FCM) using a leather foot under dry conditions. The application of site-applied floor sealers, polishes and other types of finishes routinely used to maintain resilient flooring materials will change the walking surface and consequently the SCOF value.

Sustainability

Certification Attribute	Standard	3rd party Certification/Certifier
Low Emitting Material	CDPH v1.1 (2017) a.k.a CHPS 01350	FloorScore/SCS

Performance	Standard	Requirements	Performance vs. Requirements
TVOC Range	CDPH v1.1 (2017) a.k.a CHPS 01350	<0.5 mg/m ³	Meets
Low Emitting Adhesives S-288	FloorScore®/SCAQMD	Less than 50 g/L	S-288 Exceeds - 14 g/L
Fundamental Material Safety Toxic Materials Reduction	WELL™ Feature 11 and 25	No asbestos, free of lead and phthalates (DEHP, DBP, BBP, DIDP, DNOP)	Meets

Limited Warranty

15-year Commercial Warranty when installed in strict accordance with the detailed instructions.

