

PRODUCT SPEC PAGE

Vivero™ Better with Diamond 10® Technology Luxury Flooring

Product Information

Construction	Product Line	International Product Specifications	Overall Thickness Wear Layer Thickness	Factory Finish	Installation	Maintenance Options
Solid Vinyl Tile (a.k.a. Luxury Vinyl Tile - LVT)	Vivero™ Better	ASTM F 1700, Class III, Type B embossed surface	0.080 in. (2.0 mm) 0.012 in. (0.3 mm)	Diamond 10® Coating	Full Spread Adhesives: S-288 Premium, S-240 Epoxy, S-310 Roll Strong™, S-543 High-Moisture	No Polish – No Buff Polish

Packaging

Tile Sizes	Tiles per Carton/ Coverage	Shipping Weight per Carton
4.5 in. X 48 (114.3 mm X 1219.2 mm) 6 in. X 48 in. (152.4 mm X 1219.2 mm)	24 - 36 ft² (3.35 m²) 18 - 36.1 ft² (3.35 m²)	29.07 lbs./carton (13.18 kg) 29.03 lbs./carton (13.16 kg)

Product Structure

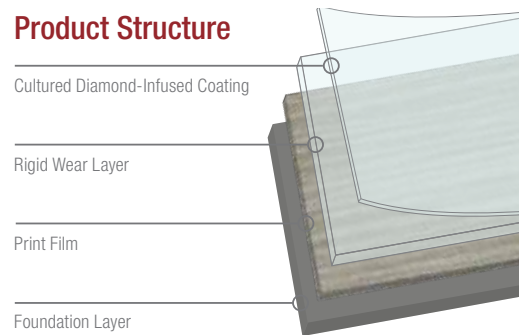

Testing

	Performance	Test Method	Requirement	Performance vs. Requirement
ASTM F 1700	Thickness	ASTM F 386	Nominal ± 0.005 in.	Meets
	Wear Layer Thickness	ASTM F 410	0.020 in. (0.5 mm) minimum for Commercial Use	Meets
	Size	ASTM F 2421	± 0.016 in. per linear foot	Meets
	Squareness	ASTM F 2421	0.010 in. maximum	Meets
	Residual Indentation	ASTM F 1914	Average less than 8%.	Meets
	Flexibility	ASTM F 137	≤ 1.0 in. diameter, no cracks or breaks	Meets
	Chemical Resistance	ASTM F 925	No more than slight change in surface dulling, attack or staining	Meets
	Heat Resistance	ASTM F 1514	ΔE < 8	Meets
	Light Resistance	ASTM F 1515	ΔE < 8	Meets
	Static Load Limit	ASTM F 970	≤ 0.005 in.	250 psi
Additional Testing	Dimensional Stability	Internal	≤ 0.018 in. per linear foot MD ≤ 0.012 in. per linear foot AMD	Meets
	Fire Test Data – Flame Spread	ASTM E 648	0.45 w/cm² or more Class I	Meets
	Fire Test Data – Smoke Evolution	ASTM E 662	450 or less	Meets
	ADA Standards for Accessible Design	Chapter 3 Section 302.1	Floor surfaces shall be stable, firm and slip resistant	Meets
	Static Coefficient of Friction*	ASTM D2047 UL 410	≥ 0.5	Meets

* Using the James Machine as described in D2047 and as directed in UL 410 for floor covering materials (FCM) using a leather foot under dry conditions. The application of site-applied floor sealers, polishes and other types of finishes routinely used to maintain resilient flooring materials will change the walking surface and consequently the SCOF value.

PRODUCT SPEC PAGE

Vivero™ Better with Diamond 10® Technology Luxury Flooring

Sustainability

Certification Attribute	Standard	3rd party Certification/Certifier
Low Emitting Material	CDPH v1.2 (2017) a.k.a CHPS 01350	FloorScore/SCS
Environmental Product Declaration (Industry EPD)	ISO 14025 and ISO 14040	Yes/ULE

Performance	Standard	Requirements	Performance vs. Requirements
TVOC Range	CDPH v1.2 (2017) a.k.a CHPS 01350	<0.5 mg/m ³	Meets
Low Emitting Adhesives S-288 S-240 S-310 Roll Strong™ S-543 Flip® Spray Adhesive	FloorScore®/SCAQMD	Less than 50 g/L	S-288 Exceeds - 14 g/L S-240 Exceeds - 10 g/L S-310 Roll Strong™ Exceeds - 0 g/L S-543 Exceeds - 0 g/L Flip® Spray Adhesive Exceeds - 0 g/L
Recycled Content	ISO 14021	Contains recycled content	29% pre-consumer recycled content
Material Ingredients/Transparency	LEED v4 (Option 1) WELL™ Feature 97	Content disclosure to 1000 ppm	Meets (See Armstrong Flooring Product Declaration)
Fundamental Material Safety Toxic Materials Reduction	WELL™ Feature 11 and 25	No asbestos, free of lead and phthalates (DEHP, DBP, BBP, DIDP, DNOP)	Meets

Limited Warranty

10-year Commercial Warranty when installed in accordance with the current edition of the Armstrong Flooring Guaranteed Installation Systems manual, F-5061.

Links

Product Transparency	www.ArmstrongFlooring.com/transparency
Email Techline	www.ArmstrongFlooring.com/flooring-techline
Visit Floor Expert	www.floorexpert.com
Installation Instructions	www.ArmstrongFlooring.com/flooring-downloads
Maintenance Instructions	www.ArmstrongFlooring.com/flooring-downloads
View Full Line	www.ArmstrongFlooring.com/lvt

