

# INSTALLATION INSTRUCTIONS

## EMPOWER™ RIGID CORE

Materials shall be installed in accordance with AUSTRALIAN STANDARDS 1884 – 2020 Floor coverings – Resilient sheet and tiles – Installation practices and these instructions.

**Please read all instructions before you begin the installation.**

### **Floating Floor Structure**

Empower™ Rigid Core Flooring is considered a “floating floor” and is installed using a floating floor system. These floors are intended for indoor use only and may be installed over virtually any existing floor structure. Expansion and contraction with changes in heat and relative humidity may occur, therefore the use of an expansion gap of 6.00mm will be required. These expansion gaps will be covered when the original skirting is replaced, or new skirting are installed. If the skirtings are left in place, a molding system will be required to cover the expansion gap.

### **KEYS TO SUCCESSFUL FLOATING/LOCKING INSTALLATION:**

- Proper conditioning of the job site is necessary. Flooring planks should not be exposed to sudden changes in temperature.
- The area to receive resilient flooring materials should be maintained between 18° C and 29° C for 48 hours before installation, during installation and 48 hours after completion. Maintain temperatures between 13° C and 38° C thereafter.
- Do not install fixtures, such as cabinets or island benches directly on top of the flooring (install fixtures first and then flooring).
- Where the point load of furnishings may exceed 200kg in any one place, (e.g. pool table, piano), Armstrong Flooring recommend that a direct glue down product should be used (E.g. 2.0mm Natural Creations or 5.0mm Natural Creations XL).
- Do not fit flush against any fixed vertical surfaces like walls, permanent fixtures, door frames, pipes or staircases, a 6mm expansion gap is required around the entire installation.
- Do not attach flooring planks to the subfloor at any point.
- When transitioning the installation through a single doorway parallel to the doorway e.g. from a hallway to a room, install an expansion joint to take pressure off the junction between the two areas.
- Do not install in wet rooms where floors fall to waste outlets.
- When installing over ceramic tiles a minimum 3mm coat of levelling screed should be used to smooth out grout joints and smooth level the tile surface.

For Empower™ Rigid Core Flooring installation, the Sub floor preparation should follow the requirements as set in the Australian Standard 1884-2020 Resilient Sheet and Tiles Installation Practices and these Armstrong Flooring installation instructions.

### **Subfloor flatness, Planeness (All subfloor types)**

When a straight edge 2000mm long is placed at any position at rest on two points on the surface, no part of the surface shall be more than 3mm below the straight edge. If there are undulations on the subfloor surface outside this, they may void the product warranty.

### **Installer Responsibility**

Prior to installation, the installer has responsibility for final inspection as to manufacture and factory finish. The installer must use reasonable selectivity and hold out or cut off pieces with deficiencies, whatever the cause, should any individual piece be doubtful, the installer should not use the piece. This inspection of all flooring pieces should be done before installation.

Carefully examine flooring for colour, finish and joint quality before installing it. If the material is not acceptable, do not install it and contact the seller immediately.

Prior to installation, the installer must determine that the job-site environment and the subfloors involved meet or exceed all applicable standards.

Where product or installation failure results from and/or is associated with incorrectly prepared subfloors, or job-site environmental deficiencies, responsibility falls with the installation contractor.

Armstrong Flooring does not warrant the installers' workmanship. Workmanship errors should be addressed to the contractor who installed the floor.

#### **Subfloors:**

The condition of the subfloor not only has an important bearing on the appearance of the finished installation but can dramatically affect the life and serviceability of the EMPOWER™ RIGID CORE Flooring. It is essential therefore that the subfloor should be dry, hard, rigid, smooth, level, clean and free of dust, grease and or any other contaminants.

EMPOWER™ RIGID CORE Flooring can be installed over most existing hard floor covering surfaces like Vinyl, linoleum and ceramic tiles. Ceramic tile should have a minimum 3mm coat of levelling screed to fill the grout joints and level the tile surface.

**Carpet or other soft flooring products are not suitable substrates.**

**Planeness:** All subfloors need to be sufficiently flat to accept a floating floor, when a two-metre straightedge is at rest at two points on any part of the floor, there is to be no more than a 3mm gap under the straightedge. Installing EMPOWER™ RIGID CORE Flooring over subfloors that do not meet the specific planeness requirements could lead to locking system failure and will not be covered by the product warranty.

#### **Concrete Subfloors:**

Concrete subfloors must be cured and completely dry. The surface must be steel trowelled to a smooth dense porous surface free of trowel marks, irregularities and undulation.

Concrete slabs in contact with fill, hard-core or the ground must have a damp-proof membrane to prevent entry of moisture. Waterproofing additives and curing compounds do not negate the need for a damp-proof membrane. New concrete slabs will dry at an approximate rate of 1.00mm per day, to be measured from the time the slab was last wet e.g. 100mm slab will take 100 days to dry. This will vary depending on weather conditions and the surface of the concrete, e.g. a burnished concrete surface will take longer to dry.

***A MOISTURE TEST SHOULD ALWAYS BE CARRIED OUT AND THE RESULTS RECORDED IN ACCORDANCE WITH THE AUSTRALIAN STANDARD 1884-2020 APPENDIX A PRIOR TO INSTALLATION***

Although Empower flooring is water proof (in that it will not warp, buckle or delaminate when exposed to water), it is not designed to be used as a moisture barrier, nor where floors fall to waste outlets, or to be installed in areas that have a risk of flooding such as spas, saunas or outdoor areas.

**If there is any doubt about moisture content of the concrete subfloor it is recommended to protect the EMPOWER™ RIGID CORE Flooring by using a 0.2mm (200 micron) polyethylene plastic sheeting, overlapped by**

**200mm and taped using a waterproof tape. The plastic sheeting should extend up the wall and be trimmed to the top side of the floor after the installation has been completed but before installing the trim.**

EMPOWER™ RIGID CORE product can be installed over radiant heating systems by following the instructions below.

1. Ensure that underfloor radiant heat surface temperature and/or radiant heat projected onto the surface of the floor does not exceed 27°C.
2. Before installing over newly constructed radiant heat systems, operate the system at maximum capacity to force any residual moisture from the cementitious topping of the radiant heat system.
3. Shut down the floor heating at least 48 hours prior to installation and make sure that the temperature in the room is at least 15°C during installation.
4. It is recommended that the radiant heat be applied in a gradual manner after installing the floor, 2 degrees per day until the desired temperature is reached. Refer to the radiant heat system's manufacturer recommendations for additional guidance.

#### **Timber Subfloor:**

All timber subfloors (including tongue & groove, particle board & plywood) must have at least 450mm of good cross ventilation under the floor to prevent distortion and movement of flooring members. Timber subfloors should be rigid, sound, free from excessive moisture, cupping and warping and constructed to relevant building standards. Old timber subfloors should have all loose boards re-nailed and badly worn or damaged boards must be replaced.

Sand all timber floors to a flat smooth finish without undulations before installing EMPOWER™ Rigid Core Flooring. Planeness is to be no more than 3mm gap under a 2-metre straightedge at rest on any part of the timber floor.

#### **Conditioning:**

Store, transport and handle the flooring planks in a manner to prevent any distortions. Distortions will not disappear over time. Store cartons flat, never on edge. Ensure that the flooring planks are lying flat at time of installation.

Proper conditioning of the job site is necessary. Allow the product to reach the area temperature by placing in the area for twenty-four hours before installing. The Flooring planks should not be exposed to sudden changes in temperature.

#### **PRE-INSTALLATION CHECKLIST**

It is the responsibility of the installer to check the material before installing:

- Is this the correct:
  - Product?
  - Colour?
  - Pattern?
  - Dimensions
- Does this stock match the customer's expectations?
- Have you read and are you following the installation recommendations?
- Has the product been allowed time to come to the same temperature as the area it is intended to be installed?

In a well-lit area inspect the EMPOWER™ Rigid Core Flooring material for visible surface or locking system defects or transportation damage prior to installation.

Any defects must be reported back to the store of purchase for an immediate replacement or refund.

Claims relating to surface / visual defects may not be accepted after installation. Contact your retailer if you have any concerns.

**PLEASE NOTE:** Locking system for EMPOWER is Angle/Angle.

## PREPARATION

1. The best option is to remove the existing skirting's, quarter round or scotia trim before installing the EMPOWER™ Rigid Core Flooring. If this is not possible a molding will be required to cover the required minimum 6.0 mm expansion gap around the edges
2. Door trims and doorjamb's should be undercut to allow the floor to move freely. Use a discarded piece of floor to support the saw blade at the correct height for undercutting. See figure 1
3. The bottom of the doors may also need to be adjusted to clear the EMPOWER™ Rigid Core Flooring.
4. Sweep / vacuum the subfloor to remove all dust and debris.

Figure: 1

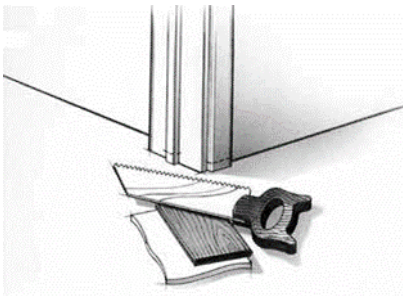
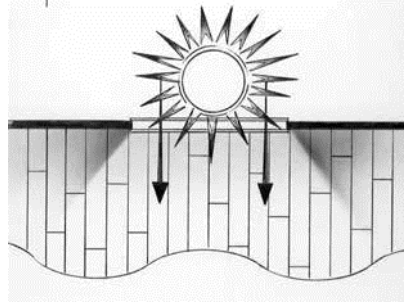

Figure: 2



## LAYOUT

Calculate the room size prior to installation, allowing an extra 10% of flooring for cutting waste.

Install EMPOWER™ Rigid Core Flooring toward the main light source (e.g. large windows or of incoming light from any windows) or, if lighting is not a concern, parallel to the longest wall in the room (Fig.2). The direction should be confirmed with the consumer before commencing the installation.

Plan the job to have as large a piece as possible on the long sides of the room, you may need to scribe the first row to the wall to achieve this balance on the opposite side wall.

**NOTE:** Use expansion joints for floor areas exceeding 150m<sup>2</sup> and/or lengths exceeding 15m.

**For the best result, make sure to always work from 3 cartons at a time mixing the planks during the installation to minimize the pattern repeat.**

## Required Cutting Tools

1. Can be cut using a score and snap method, use a sharp utility knife, cut both sides and snap.
2. Guillotine plank cutter
3. A table saw with a good quality 60 tooth carbide-tipped cutting blade, with dust extraction.
4. A drop saw, with dust extraction system attached.
5. Jig saw with a fine blade to make intricate cuts
6. Mark the board using a square to keep your cut line straight.
7. Cut the marked piece in another area to keep the sawdust away from the installation site.

## Other tools

1. Pencil / tape measure, Carpenters square and long straightedge.
2. Utility knife for cutting score and snap, trimming to clean edges.
3. Pull bar and Tapping block. (use an off-cut piece of plank so as not to damage locking profile, gently tap)
4. Spacers to maintain expansion gap around the edge
5. Bradding gun to fix skirtings or quads/ mouldings
6. White rubber mallet (for use with a tapping block)
7. Vacuum cleaner / broom / broom and dustpan

## PRECAUTIONS

**WARNING!** Sawing, sanding, machining of this product produces respirable dust, which may include crystalline silica. Crystalline silica is known to cause cancer. The use of appropriate personal protective equipment and dust masks are recommended.

Where power tools are used, they should be equipped with a vacuum dust collector and used in a well-ventilated area. The use of appropriate personal protective equipment and dust masks are highly recommended. Avoid dust contact with eyes and skin.

For further information Refer to Australian Standard 1884-2020 Section 4.3 Silica dust control.

## INSTALLING THE FIRST ROW

PLEASE NOTE: Locking system for EMPOWER is Angle/Angle.

1. Begin on the left side of the room and work towards the right.
2. Lay the first full piece with the small, tongue side facing the wall.
3. Install second and subsequent full pieces in the first row by angling the end tongue into the end groove of the first plank and locking into place.
4. Use spacers along all sides that butt up against walls to maintain 6.0 mm expansion gap (see figure 3).
5. Continue laying boards in the first row until you need to cut the last piece.
6. Measure the distance between the wall and the face surface of the last board. Subtract 6.0 mm and cut the board using the Guillotine plank cutter or drop saw. (See cutting instructions above and figure 4),
7. If this distance is less than 250 mm go back to the first full plank and cut approximately 250 mm from the end closest to the starting wall. This will leave a longer piece at the end of the first row.

Figure: 3



Figure: 4

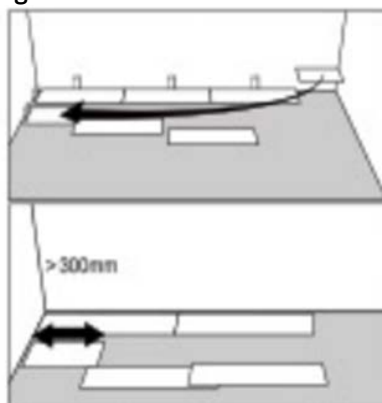
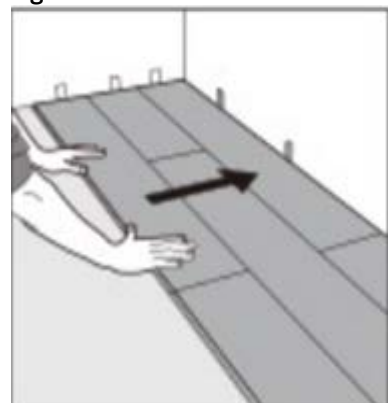

Figure: 5



## INSTALLING REMAINING ROWS

1. Begin the second row of planks with the piece cut from the last piece in the first row. If the piece is shorter than 250mm cut a new plank in half and use it to begin the second row. Whenever practical, use the piece cut from the preceding row to start the next row. End joints of all boards should be staggered 250mm or more.

2. Install the long end of the first board at an angle to the board in the previous row. Keep this board at its natural angle, which is slightly raised off the subfloor. Use a scrap piece of EMPOWER™ Rigid Core Flooring to support the row if needed.
3. Continue installing full boards in the second row by angling the short end of the next board in the row to lock into the previous board. Position the board so that the long side of the board is close to boards in the previous row and overlapping the groove of the boards in the previous row. Avoid any gapping between the planks, as any gapping can compromise the whole installation.
4. Angle up and push forward until the boards lock together. A tapping block may be used to fully engage the locking system of the planks. (Use an off cut as a tapping block to avoid damage to the locking system)
5. Continue installing full boards in the second and subsequent rows until you reach the wall on your right.
6. Measure and mark the last piece, cut and install.
7. It may be necessary to use a pull bar to ensure end joints are engaged properly.
8. Occasionally as you go around an island bench or into a small area it may be necessary to install backwards, this is more difficult. This may be done by sliding the grooves under the tongues and working them right to left, the use a tapping block to help engage the locking system may be necessary.

**Warning:** Failure to properly line up the end joint and attempting to force it in while out of alignment could result in permanent damage to the end joint. PLEASE NOTE: Locking system for EMPOWER is Angle/Angle.

#### Installing the Last Row

1. The last row of the installation will need to be cut lengthwise.
2. Place the row of planks to be fitted on top of the last row of installed planks. Use a piece of the plank as a scribe to trace with a pencil the contour of the wall. See figure 6
3. Cut the boards to fit allowing for the required expansion space is best done using a table saw.
4. Lay the piece into position (you may need to use a pull bar to properly engage and lock in the joints).

Figure 6

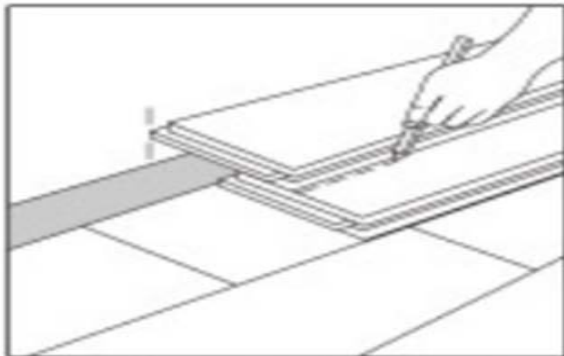

#### Edge finishing

1. To make holes for pipes, measure the diameter and position of the pipe, drill the hole approximately 6.0mm larger than the diameter of the pipe. To allow piece to be installed, cut a piece from the back side of the pipe using a slight 'v' shape. Sit piece into place, insert the v piece in behind the pipe and glue in place with woodwork glue, use spacing wedges to hold the 'v' piece in place while the adhesive sets.
2. If skirtings were removed reinstall over the top of the expansion gap (do not fix skirting to the flooring, fix to the wall).
3. Where skirtings were not removed install colour matched EMPOWER™ Rigid Core Flooring scotia trims from Armstrong Flooring (do not fix skirting to the flooring, fix to the wall).

## Disassembly

Separate the whole row by lifting it up delicately at an angle. To separate the planks, leave them flat on the ground and slide them apart. If the planks do not separate easily, you can lift the plank slightly and slide apart.

## BATHROOM INSTALLATION RECOMMENDATIONS

EMPOWER™ Rigid Core Flooring Planks are suitable for installation in bathrooms and toilets, install as per normal recommendations, bathrooms and laundries, flat floors only, no falls to waste.

1. At the junction where EMPOWER™ Rigid Core Flooring are installed against shower bases or baths, the following method is recommended.
  - a) Leave a 3.0mm expansion gap against shower bases or baths. Normal 6 mm gaps along other walls.
  - b) Completely fill expansion gap against shower base or baths with colour matched 100% silicone caulk by following the manufacturer's recommendations. When applying caulk, it is helpful to first apply a strip of masking tape parallel to and approximately .80mm from the edge of the flooring. Then fill the expansion zone with caulk, remove the excess with a plastic scraper or putty knife and remove the tape.

### Toilets

1. The toilet should be removed before installing the flooring.
2. Allow a 6.5 mm expansion gap between the flooring edge and the toilet flange. Completely seal the gap with 100% silicone caulk.

## CARING FOR YOUR FLOOR:

- Wipe up spills as soon as possible.
- Floors, may become slippery when wet, allow time for floor to dry after washing.
- Never use highly abrasive scrubbing tools on any resilient floor.
- Do NOT use detergents, abrasive cleaners, or "mop and shine" products. These products may leave a dull film on your floor.
- Frequency and type of maintenance required depends on traffic flow, application, environmental conditions and customer requirements. Light and accent colours can require more maintenance, where practical choose darker, more camouflaging colours.

### Protection:

- All flooring should be protected during the construction period. Armstrong Flooring does not recommend covering our PVC floor or wall products with plastic materials (such as builder's plastic, corflute®, carpet protector film etc), the use of cardboard is recommended, do not tape protection directly to the flooring.
- Sand and grit are abrasive and can damage floors; stopping dirt at the entrance means less dirt trafficked through the building, protecting your investment and helping keep maintenance costs down.
- Use walk-off mats that are as wide as the doorway entrances and long enough (min. 3 average paces) to trap dirt before reaching the resilient floor. Ensure that walk-off mats are cleaned frequently.
- **Do not use Rubber Backed walk off mats**  
Rubber products such as chair feet, tyres & black rubber backed mats can stain any flooring (including vinyl), do not leave these in contact with flooring.

**Protection continued:**

- Ensure all furniture legs have well maintained non-abrasive feet, use of felt protectors is recommended. Exposed metal legs can damage flooring.
- Ensure castors on office/ dental type chairs are kept clean, these types of wheels can damage the surface of flooring.
- **Do not:** Polish, Dry burnish, Spray buff or Scrub using a high-speed polisher/scrubber with abrasive pads/brushes
- **Do not use:** Highly acidic, alkali, caustic or solvent agents such as hydrochloric/sulfamic acid, toilet bowl cleaner, paint stripper, benzene, toluene, acetone or strong scouring powders, as these will damage the floor.
- When moving appliances or heavy furniture it is always wise to lay a plywood panel, or similar, on your floor and “walk” the item across it. This protects your floor from scuffing, gouging and tears.

**WARNING!** Sawing, sanding, machining of this product produces respirable dust, which may include crystalline silica. Crystalline silica is known to cause cancer. The use of appropriate personal protective equipment and dust masks are recommended.

Where power tools are used, they should be equipped with a vacuum dust collector and used in a well-ventilated area. The use of appropriate personal protective equipment and dust masks are recommended. Avoid dust contact with eyes and skin.

**For further information Refer to Australian Standard 1884-2020 Section 4.3 Silica dust control.**

**ARMSTRONG FLOORING PTY LTD**

**FLOORCOVERINGS, ADHESIVES & ACCESSORIES MANUFACTURED IN AUSTRALIA AFTER 1st JANUARY, 1984 DO NOT CONTAIN ASBESTOS**



**WARNING**

Vinyl flooring and adhesives manufactured in Australia prior to 1st January, 1984 may contain asbestos.

Do not sand, dry sweep, dry scrape, drill, saw, beadblast, or mechanically chip or pulverise existing resilient flooring, backing, lining felt or asphaltic ‘cut-back’ adhesives.

These products may contain either **asbestos fibres** or **crystalline silica**.

Avoid creating dust. Inhalation of such dust is a cancer and respiratory tract hazard.

Unless positively certain that the product to be removed is a non-asbestos containing material, you must presume it contains asbestos. Regulations may require that the material be tested to determine asbestos content.

**Where do I go to find out more about asbestos?**

Asbestos Awareness [www.asbestosawareness.com.au](http://www.asbestosawareness.com.au) – provides information

on a state by state basis about the dangers of asbestos, asbestos removal, who to contact and other important information.

**NOTE:** Vinyl flooring manufactured in Australia after January 1, 1984, **DOES NOT** contain asbestos. However, regulations, codes and directives as to the best method of handling asbestos do exist and it is the obligation of the installer to ensure that practices used are safe, without risk to health, and meet all legal requirements.

**Disclaimer—Asbestos issues**

The warnings and guidance contained in these instructions in relation to the potential for asbestos in floorcovering materials are given in good faith. However, regulations, codes and directives as to the best method of handling asbestos are under continual revision. It is the obligation of the installer to ensure that practices used are safe, without risk to health, and meet all legal requirements.

Armstrong Flooring Pty Ltd accepts no liability for any loss, costs, expense or injury, however incurred, arising from the presence of any asbestos in any floorcovering materials or asphaltic ‘cut-back’ adhesives and/or any reliance placed upon the procedures and recommended practices contained in these instructions.

Armstrong Flooring Pty Ltd  
 29 – 39 Mills Road, Braeside, 3195 Victoria Australia  
 For further information and samples:  
 Australia Freecall 1800 632 624  
 Email [customer\\_services@armstrongflooring.com](mailto:customer_services@armstrongflooring.com) or contact us on the web  
[www.armstrongflooring.com.au](http://www.armstrongflooring.com.au)