

Product Information

Construction - Luxury Vinyl Tile

Product Line - ProMerica™ 6

International Specifications - ASTM F1700, Class II, Type B embossed surface

Overall/Wear Layer Thickness - 0.080 in. (2.0 mm), 0.006 in. (0.15 mm)

Factory Finish - Urethane Plus

Installation - Full Spread Adhesives: S-295, S-315 Roll Strong™, Flip® Spray

Maintenance Options - No Polish - No Buff, No Polish - Spray Buff, Polish

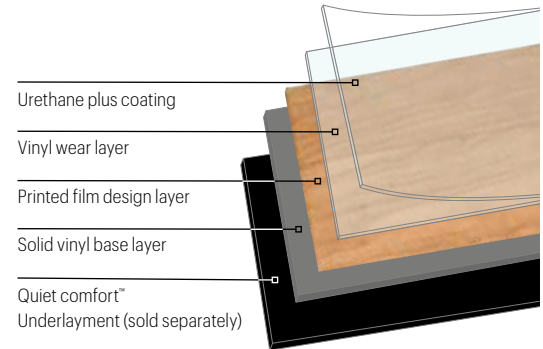

Packaging

Size	Tile per Carton/Coverage	Shipping Weight per Carton
6 in. x 36 in. (152 mm x 914 mm)	24 - 35.95 ft ² (3.4 m ²)	30.7 lbs./carton (13.93 kg.)

Testing

Performance	Test Method	Requirement	Performance vs. Requirement
Thickness (w/ back layer)	ASTM F386	Nominal ± 0.005 in.	Meets or Exceeds
Size	ASTM F2055	± 0.016 in. per linear foot	Meets
Squareness	ASTM F2055	0.010 in. maximum	Exceeds
Flexibility	ASTM F137	≤ 1.0 in. diameter, no cracks or breaks	Exceeds
Dimensional Stability	ASTM F2199	≤ 0.020 in. per linear foot	Meets
Chemical Resistance	ASTM F925	No more than slight change in surface dulling, attack or staining	Meets or exceeds
Resistance to Heat	ASTM F1514	ΔE < 8	Exceeds
Resistance to Light	ASTM F1515	ΔE < 8	Exceeds
Additional Testing			
Static Load Limit	ASTM F 970	≤ 0.005 in.	250 psi
Fire Test Data – Flame Spread	ASTM E648	0.45 W/cm ² or more Class 1	Meets
Fire Test Data – Smoke Evolution	ASTM E662	450 or less	Meets

Sustainability and Well-Being

Certification Attribute	Standard	3rd party Certification/Certifier
Low Emitting Material	CDPH v1.1 (2017) a.k.a CHPS 01350	FloorScore/SCS
Environmental Product Declaration (Industry EPD)	ISO 14025	Yes/ASTM International
Low Emitting Material – Adhesive (S-295 & S-319)	CDPH v1.1 (2017) a.k.a CHPS 01350	FloorScore/SCS

Performance	Standard	Requirements	Performance vs. Requirement
TVOC Range	CDPH v1.1 (2017) a.k.a CHPS 01350	<0.5 mg/m ³	Meets
Low Emitting Adhesives S-295 Premium S-319 RollStrong™ Flip® Spray	FloorScore®/SCAQMD	Less than 50 g/L	S-295 Exceeds – 0 g/L S-319 Exceeds – 0 g/L Flip® Exceeds – 0 g/L
Material Ingredients/Transparency	LEED v4 (Option 1) WELL™ Feature 97	Content disclosure to 1000 ppm	Meets (See Armstrong Flooring Product Declaration)
Fundamental Material Safety Toxic Materials Reduction	WELL® Feature 11 and 25	No asbestos, free of lead and phthalates (DEHP, DBP, BBP, DIDP, DNOP)	Meets
Sourcing of Raw Materials	LEED v4	Extended Producer Responsibility	Meets – See Armstrong On & On™ Floor Recycling Program
Recycled Content	ISO 14021	Contains recycled content	Meets – 10% Pre-consumer

Limited Warranty

15-Year Limited Residential & 5-Year Limited Commercial Warranty.

Visit [ArmstrongFlooring.com/pro](https://www.armstrongflooring.com/pro)

for complete Product, Technical, Adhesives, Installation & Maintenance recommendations.

F10552-122

Armstrong and the Armstrong logo are under license from AWI Licensing LLC. | All other trademarks are owned by AFI Licensing LLC. | © 2022 AFI Licensing LLC. FloorScore® is a registered trademark of the Resilient Floor Covering Institute. | LEED® is a registered trademark of the United States Green Building Council.

